

CAPITAL SPORTS

Amazor M Power Rack



Multifunkčný stojan



10034964

Vážený zákazník,

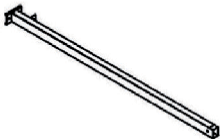
Blahoželáme k nákupu tohto zariadenia. Pozorne si prečítajte príručku a dodržujte nasledujúce rady, aby ste predišli poškodeniu prístroja. Nenesieme zodpovednosť za škody spôsobené nedodržaním pokynov a nesprávnym použitím.

ZOZNAM BALENIA

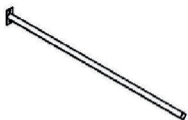
Kartón A		
SKU: 70003179 219*24*16.5 cm		
24. 2PCS 	25. 2PCS 	27. 1PC 

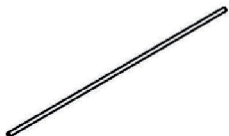
Kartón B		
SKU: 70003180 204*36*15 cm		
3. 1PC 	4. 1PC 	10. 2PCS 
26. 2PCS 		

Kartón C

SKU: 70003181 | 176*25*15.5 cm

1. 1PC



2. 2PCS

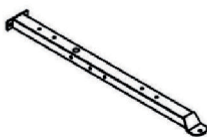

8. 2PCS

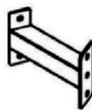

12. 2PCS



14. 2PCS



29. 2PCS

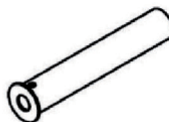

SCREWS KIT

MANUAL

Kartón D

SKU: 70003182 | 90.5*39*14.5 cm

6. 2PCS

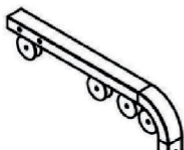

15. 2PCS

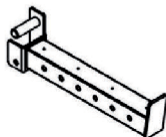

16. 2PCS

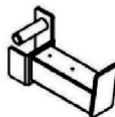

28. 8PCS

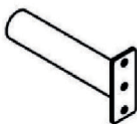

30. 4PCS

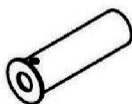

Kartón E

SKU: 70003183 | 121*41.5*18 cm

5. 2PCS

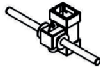

7. 2PCS

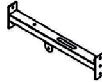

9. 1PC



11. 1PC



13. 2PCS



17. 1PC



18. 1PC



19. 1PC



20. 2PCS



21. 2PCS



22. 2PCS



23. 2PCS



31. 6PCS



32. 4PCS



33. 4PCS



34. 6PCS



35. 14PCS



36. 4PCS

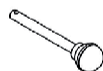

37. 2PCS



38. 20PCS



39. 4PCS



40. 2PCS



41. 2PCS

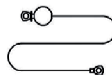

42. 2PCS

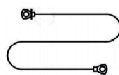

43. 6PCS



44. 14PCS



45. 4PCS











VÝROBCA

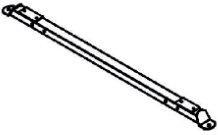
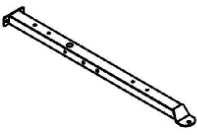
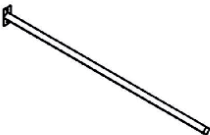
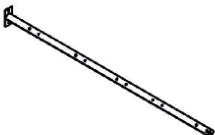
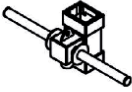
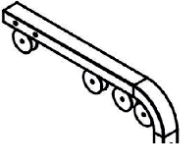
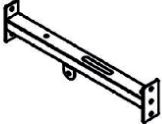

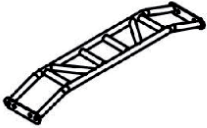
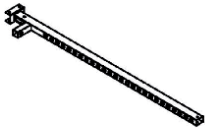



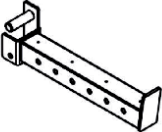



Chal-Tec GmbH, Wallstraße 16, 10179 Berlín, Nemecko



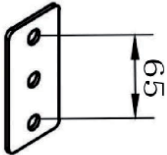
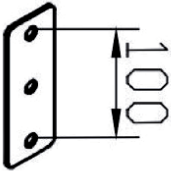
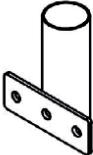
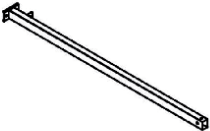



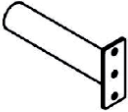
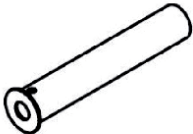
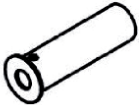

BEZPEČNOSTNÉ INŠTRUKCIE



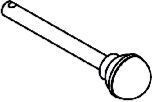
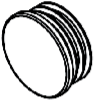
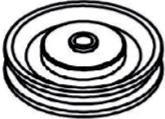

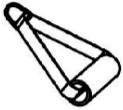
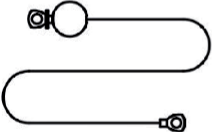
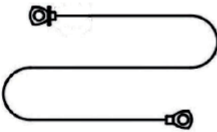

- Uschovajte si tento návod na bezpečnom mieste pre prípad potreby.
- Zariadenie prosím nemontujte ani nepoužívajte, kým si dôkladne a pozorne neprečítate tento návod. Bezpečnosť a účinnosť sa dá dosiahnuť iba vtedy, keď je zariadenie správne zostavené, udržiavané a používané. Je vašou zodpovednosťou zabezpečiť, aby boli všetci používatelia informovaní o všetkých varovaniach a preventívnych opatreniach.
- Pre bezpečné použitie je potrebný stabilný a vyrovnaný povrch. Chráňte svoju podlahu podložkou. Nepoužívajte zariadenie vo vlhkých priestoroch, ako je sauna pri bazéne atď. Z bezpečnostných dôvodov musí mať zariadenie minimálne 0,6 metra voľného priestoru všade naokolo.
- Pred začatím akéhokoľvek cvičebného programu sa musíte poradiť so svojím lekárom, aby ste zistili, či máte nejaké fyzické alebo zdravotné podmienky, ktoré by mohli predstavovať riziko pre vaše zdravie a bezpečnosť alebo vám zabrániť v správnom používaní prístroja. Ak užívate lieky, ktoré ovplyvňujú váš srdcový rytmus, krvný tlak alebo hladinu cholesterolu, sú nevyhnutné rady lekára.
- Všímajte si signály vášho tela. Nesprávne alebo nadmerné cvičenie môže poškodiť vaše zdravie. Prestaňte cvičiť, ak sa u vás vyskytnie niektorý z nasledujúcich príznakov: bolesť, tlak na hrudi, nepravidelný srdcový rytmus, extrémna dýchavičnosť, pocit točenia hlavy, závrat alebo nevoľnosť. Ak sa u vás vyskytne niektorý z týchto stavov, skôr ako budete pokračovať v cvičebnom programe, musíte sa poradiť so svojím lekárom.
- Necvičte ihneď po jedle.
- Udržujte deti a domáce zvieratá v dostatočnej vzdialenosti od zariadenia, zariadenie musia montovať a používať iba dospelí.
- Zariadenie je určené iba na domáce použitie.
- Zariadenie nie je vhodné na terapeutické použitie, môže sa používať iba na cvičenia uvedené v pokynoch na tréning.
- Pri používaní prístroja noste správne oblečenie a športovú obuv. Nenoste voľné oblečenie, ktoré by sa mohlo zachytiť o zariadenie alebo ktoré môže obmedziť alebo zabrániť pohybom.
- Pri cvičení držte chrbát vystretý.

ČASTI

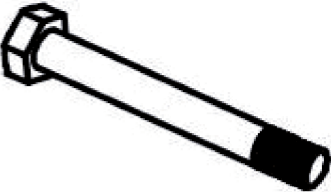
 <p>1 x1</p>	 <p>2 x2</p>	 <p>3 x1</p>	 <p>4 x1</p>
 <p>5 x2</p>	 <p>6 x2</p>	 <p>7 x2</p>	 <p>8 x2</p>
 <p>9 x1</p>	 <p>10 x2</p>	 <p>11 x1</p>	 <p>12 x2</p>
 <p>13 x2</p>	 <p>14 x2</p>	 <p>15 x2</p>	 <p>16 x2</p>

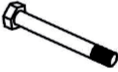
 <p>17 x1</p>	 <p>18 x1</p>	 <p>19 x1</p>	 <p>20 x2</p>
 <p>21 x2</p>	 <p>22 x2</p>	 <p>23 x2</p>	 <p>24 x2</p>
 <p>25 x2</p>	 <p>26 x2 L=1750mm</p>	 <p>27 x1 L=1779mm</p>	 <p>28 x8</p>
 <p>29 x2</p>	 <p>30 x4</p>	 <p>31 x6</p>	 <p>32 x4</p>

 <p>33 x4</p>	 <p>34 x6</p>	 <p>35 x14</p>	 <p>36 x4</p>
 <p>37 x2</p>	 <p>38 x20</p>	 <p>39 x4</p>	 <p>40 x2</p>
 <p>41 x2 L=5560mm</p>	 <p>42 x2 L=3100mm</p>	 <p>43 x2</p>	 <p>44 x6</p>
 <p>45 x4</p>			

46	M10 x 65	x8	
47	M10 x 60	x4	
48	M10 x 70	x18	
49	M10 x 75	x8	
50	M10 x 85	x2	
51	M10 x 90	x4	
52	M10 x 95	x4	
53	M12 x 70	x4	
54	M12 x 95	x8	
55	M12 x 105	x2	
<hr/>			
56	M10 x 55	x2	
57	M10 x 50	x16	
58	M10 x 35	x2	
59	M10 x 30	x2	
<hr/>			
60	M10 x 20	x6	
61	M10 x 25	x2	
<hr/>			
62	M10	x138	
63	M12	x28	
<hr/>			
64	M10	x68	
65	M12	x14	

MONTÁŽ

